

REVISIONS				
ZONE	REV.	DESCRIPTION	DATE	APPROVED
	1	INITIAL RELEASE	4/19/2019	N.BRANNIGAN

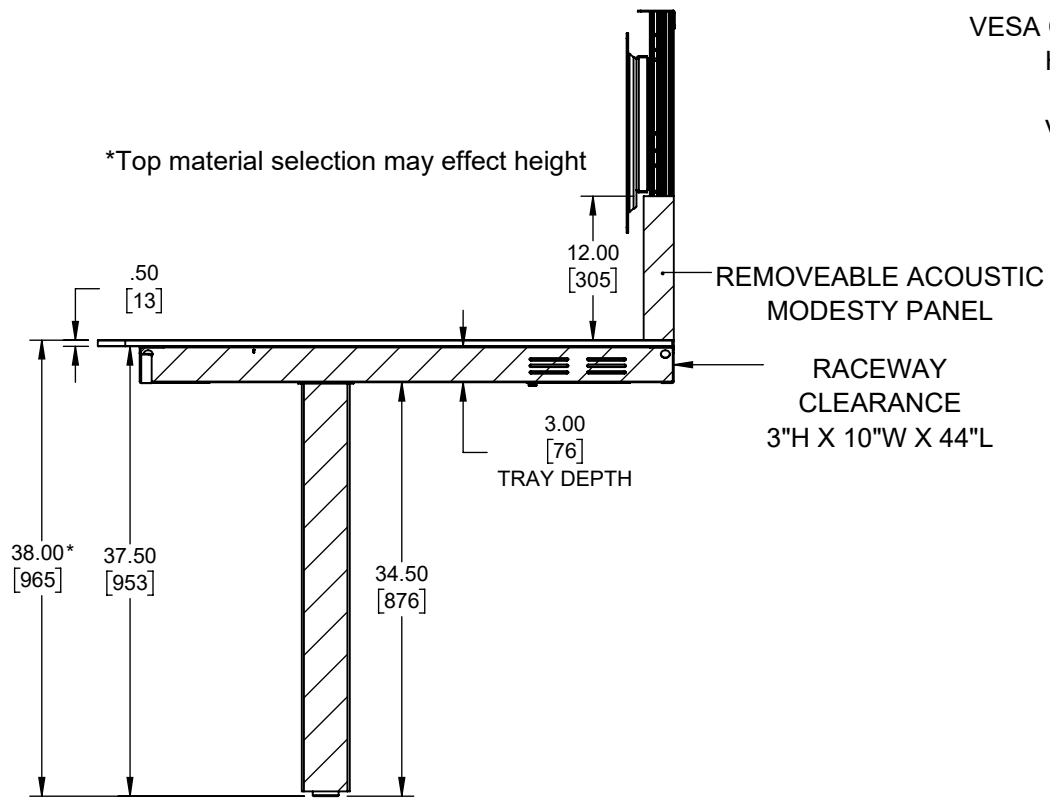
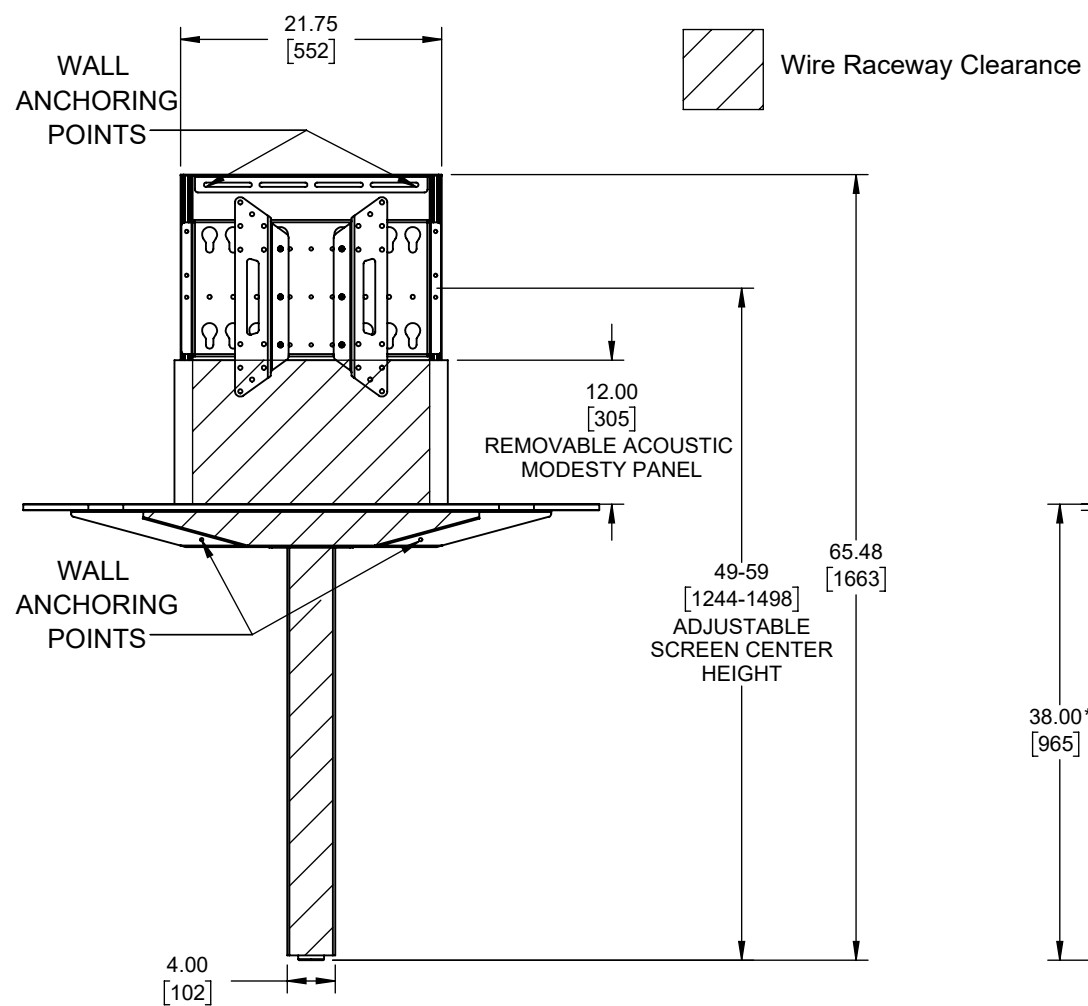
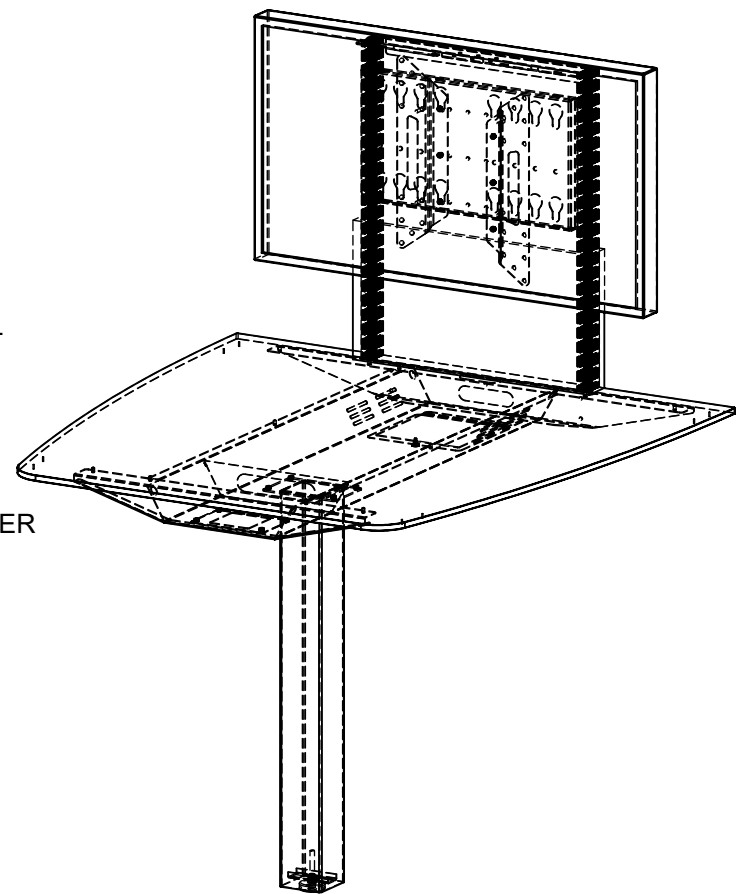
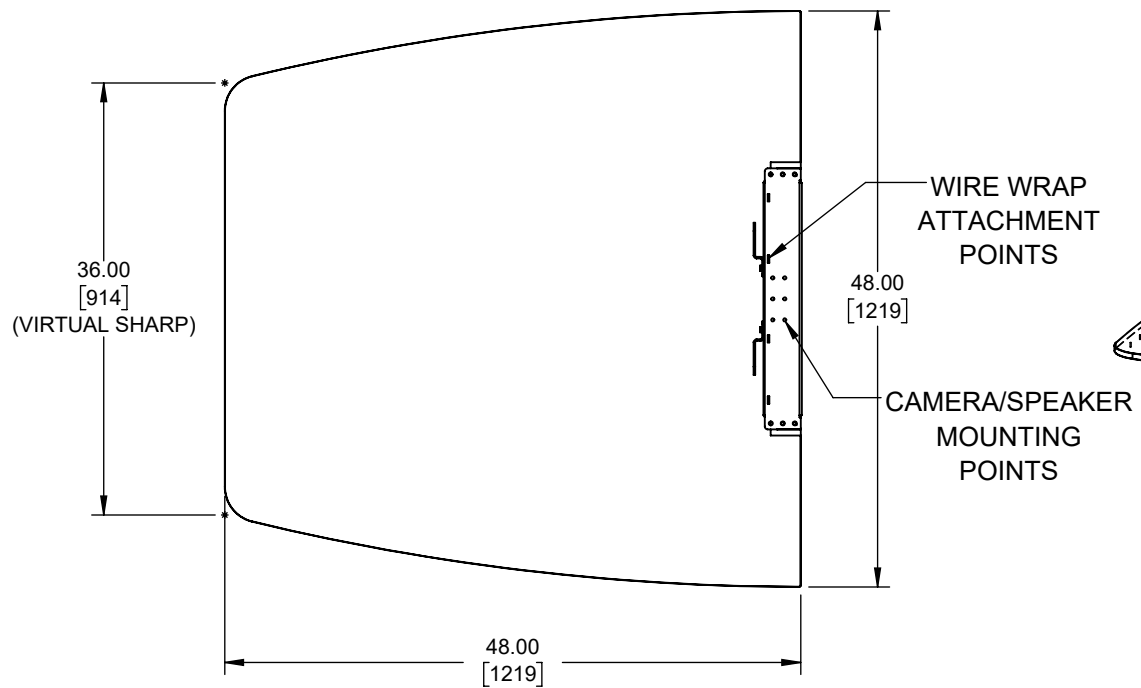
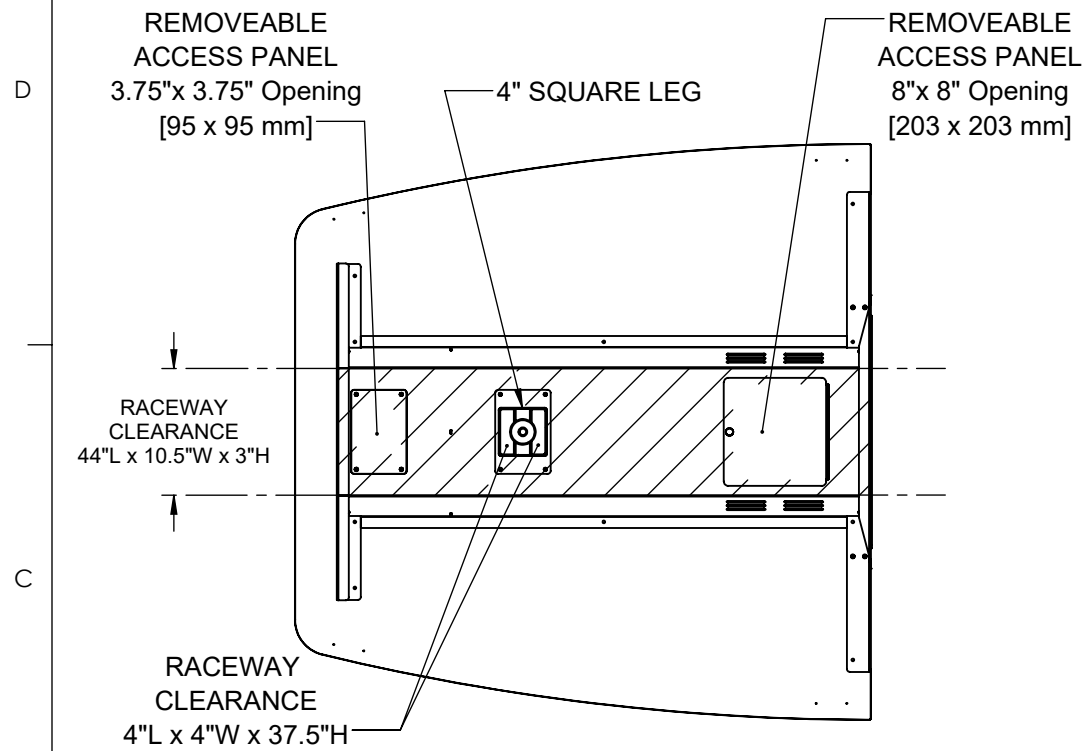

VESA COMPLIANT:  
Horizontal: 200, 250, 300, 350, 400, 450, 500, 550, 600mm  
Vertical: 200, 300, 350, 400mm

PROPRIETARY INFORMATION: THIS MATERIAL AND THE CONTENTS THEREOF ARE CONSIDERED THE PROPERTY OF SALAMANDER DESIGNS, AND THE DISCLOSURE TO UNAUTHORIZED INDIVIDUALS OR DISSEMINATION, PUBLICATION, OR COPYING THEREOF IS PROHIBITED WITHOUT PRIOR WRITTEN CONSENT BY SALAMANDER DESIGNS OF BLOOMFIELD, CONNECTICUT.

		811 BLUE HILLS AVE. BLOOMFIELD, CT 06002 T/ 860.313.0525 / F/ 860.313.0526		SIZE <b>B</b>
TITLE: <b>WALL STATION - COUNTER HEIGHT SINGLE MOUNT</b>				
MATERIAL SEE NOTE		SURFACE TREATMENT		
DRAWN BY N.BRANNIGAN	DATE 5/1/19	HEAT TREATMENT		
ENGINEER XXX	CHECKED BY	SCALE XX	SHEET 1 OF 1	
DRAWING NUMBER <b>WS40AM1/G/C/XX</b>				REV 1