

IPSWDHD-MW

IP Speaker with HD Display

Overview

Engage and capture attention with the PoE+ IP Speaker with HD Display. Employ custom graphics and images for day-to-day and critical announcements using the high-resolution LCD display, RGB flashing bar, and 8 inch speaker.

The IPSWDHD-MW is typically installed in classrooms or any average sized room, easily integrates with VoIP phone systems, approved 3rd party software, and includes ClockWise Campus software with purchase.

Description

2:46 PM
42

DISPLAY

1920 x 720 high resolution full-color LCD screen. Angled display to reduce glare.



MICROPHONE

Hands-free two-way intercom.



FLASHERS

RGB flashing LED bar. Customize for additional visual messaging in any color.



AUDIO

8" high-efficiency speaker audio coverage up to 600ft². Digitally enhanced bass.



PERIPHERAL INTEGRATION

Connect a strobe, motion sensor, electronic lock, call button, etc.



SOFTWARE

ClockWise Campus software included. Compatible with approved third-party software.



SIP INTEGRATION

SIP-enabled. Easily interfaces with VoIP / SIP phone systems.



LIGHT SENSOR

Auto-dimming display.

Solutions

- Paging
- Intercom
- Bell scheduling
- Code alerts
- Emergency notification
- Access control
- Security monitoring
- Music streaming

Additional Features

- Built-in web server
- Full multicast and broadcast support
- Requires Cat5 or Cat6 cable
- Back enclosure is included
- Atomic time

Compatible Peripherals

- **Strobe kit**
- AND-STROBE-KIT-1
- **Call Button Kit**
- AND-BTN-KIT-1
- **Call Button Kit with Mic**
- BTN-KIT-MIC-ND

Dimensions

(Dimensions are subject to change)

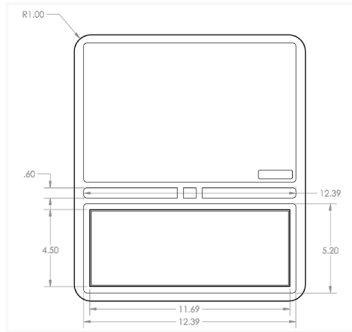

Front

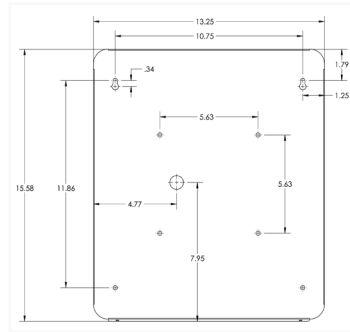

Back

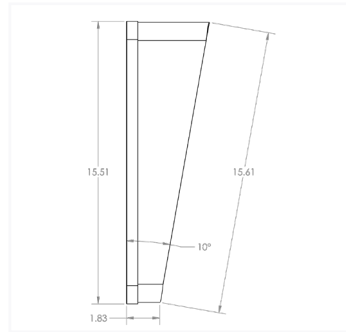

Side

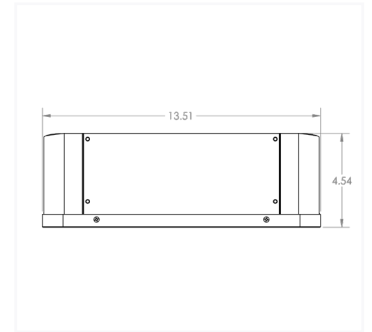

Top

Specifications

Due to continual product development, specifications are subject to change without notice.

| | |
|---------------------------|--|
| Power Input | PoE+ (IEEE802.3at) 30.0W |
| Ethernet I/F | 10/100/1000 Mbps |
| Speaker Size | 8" |
| Frequency Response | 60 Hz - 17 kHz |
| Audio Payload Types | G711, A-law and μ -law |
| Average Sensitivity | 95dB, 1W / 1 M |
| Supported Protocols | SIP, IPv4, IPv6, 802.1X, HTTP, SLP, TFTP, NTP, SNMPV1 & SNMPV2c, DHCP, IGMP, ICMP, TCP/IP, LLDP-MED, UDP, MDNS & MDNS-SD |
| General Purpose Interface | 2 GPI: 1 via RJ-11, 1 via Cable Harness 1 GPO: Contact Closure or 12 VDC / 15 VDC |
| Audio Interface | Stereo Analog Line Out Stereo Analog Line In |
| Operating Temperature | 14° TO 122° F (-10° TO 50° C) |
| Dimensions | 13.51" W x 15.58" H x 4.54" D |
| Weight | 10.5 lbs (4.7 kg) |
| Warranty | 2 Year Limited |

